

To Find	Module	Imperial
PCD	= No. of TEETH x MOD (mm)	= $\frac{\text{No. of TEETH}}{\text{DP}}$ (ins)
ØD	= (No. of TEETH + 2) x MOD (mm)	= $\frac{\text{No. of TEETH} + 2}{\text{DP}}$ (ins)
DP	= $\frac{25.4}{\text{MODULE}}$	= $\frac{\pi}{\text{CP}''}$
MODULE	= $\frac{\text{CP}}{\pi}$ (mm)	= $\frac{25.4}{\text{DP}}$
No. of TEETH	= PCD ÷ MODULE (mm)	= PCD'' x DP
CP	= MODULE x π (mm)	= $\frac{\pi}{\text{DP}}$ (ins)
ADDENDUM	= MODULE (mm)	= $\frac{1}{\text{DP}}$ (ins)
DEDENDUM	= 1.4 x MOD (0.25-1 MOD) = 1.25 x MOD (1.25-8 MOD)	= $\frac{1.4}{\text{DP}}$ (100-24 DP) = $\frac{1.25}{\text{DP}}$ (20-6 DP)

Center distance between mating gears = (PCD Gear A+PCD Gear B) / 2

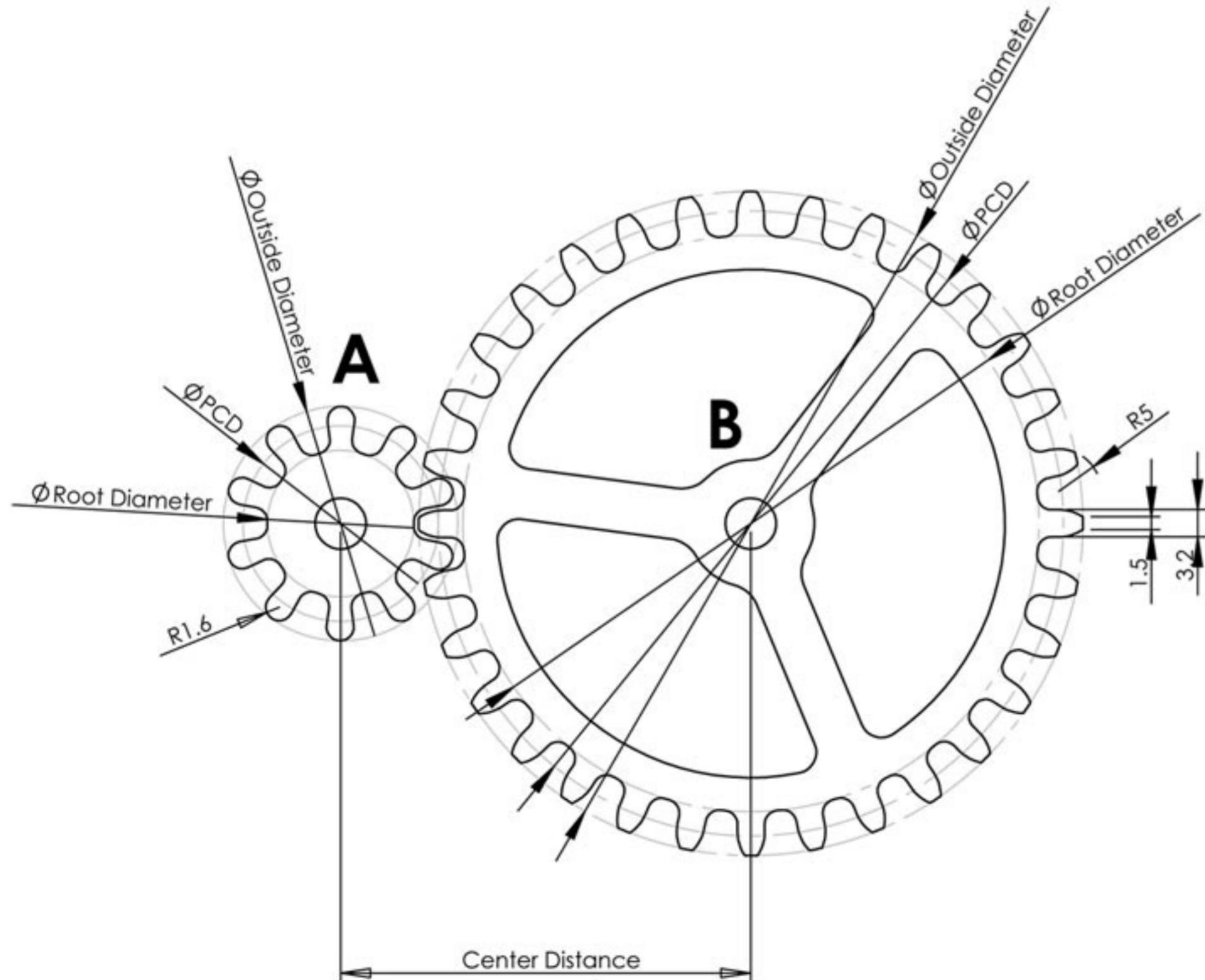

Number of Teeth	Pitch Circle Diameter	Outside Diameter	Root Diameter	Tooth Thickness	Root Radius	Module
8	18.4	23	12.65	3.2	1.6	2.3
10	23	27.6	17.25	3.2	1.6	2.3
12	27.6	32.2	21.85	3.2	1.6	2.3
14	32.2	36.8	26.45	3.2	1.6	2.3
15	34.5	39.1	28.75	3.2	1.6	2.3
16	36.8	41.4	31.05	3.2	1.6	2.3
18	41.4	46	35.65	3.2	1.6	2.3
20	46	50.6	40.25	3.2	1.6	2.3
22	50.6	55.2	44.85	3.2	1.6	2.3
24	55.2	59.8	49.45	3.2	1.6	2.3
25	57.5	62.1	51.75	3.2	1.6	2.3
28	64.4	69	58.65	3.2	1.6	2.3
30	69	73.6	63.25	3.2	1.6	2.3
32	73.6	78.2	67.85	3.2	1.6	2.3
34	78.2	82.8	72.45	3.2	1.6	2.3
38	87.4	92	81.65	3.2	1.6	2.3
40	92	96.6	86.25	3.2	1.6	2.3
45	103.5	108.1	97.75	3.2	1.6	2.3
50	115	119.6	109.25	3.2	1.6	2.3
54	124.2	128.8	118.45	3.2	1.6	2.3
60	138	142.6	132.25	3.2	1.6	2.3
64	147.2	151.8	141.45	3.2	1.6	2.3
70	161	165.6	155.25	3.2	1.6	2.3
72	165.6	170.2	159.85	3.2	1.6	2.3
75	172.5	177.1	166.75	3.2	1.6	2.3
80	184	188.6	178.25	3.2	1.6	2.3
84	193.2	197.8	187.45	3.2	1.6	2.3
90	207	211.6	201.25	3.2	1.6	2.3
96	220.8	225.4	215.05	3.2	1.6	2.3
100	230	234.6	224.25	3.2	1.6	2.3

The box on each page is 25.4mm (1 inch) square



Brian Law's Woodenclocks
A collection of Spur Gears based on the tooth profiles used in the woodenclocks

Brian Law February 2011

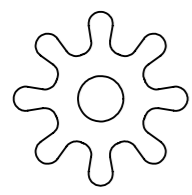

8 Teeth

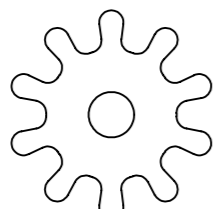

10 Teeth

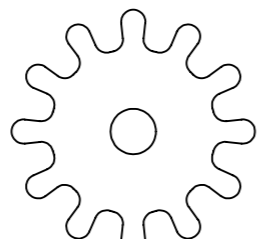

12 Teeth

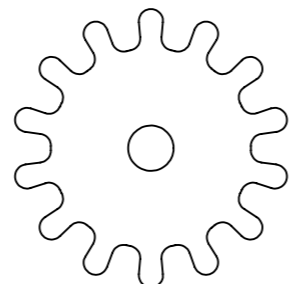

14 Teeth

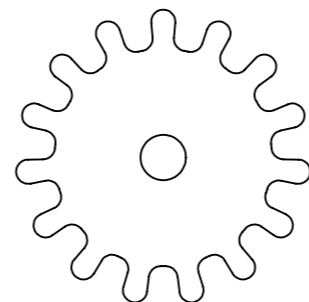

15 Teeth

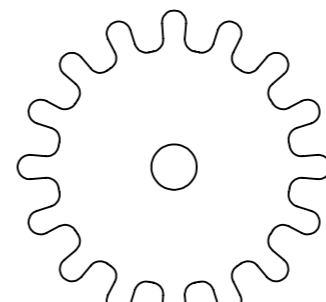

16 Teeth

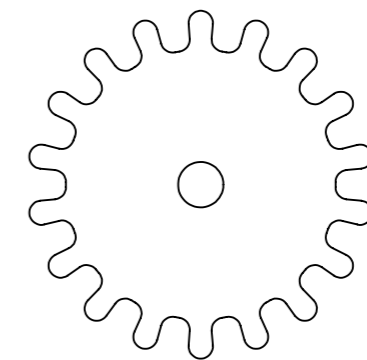

18 Teeth

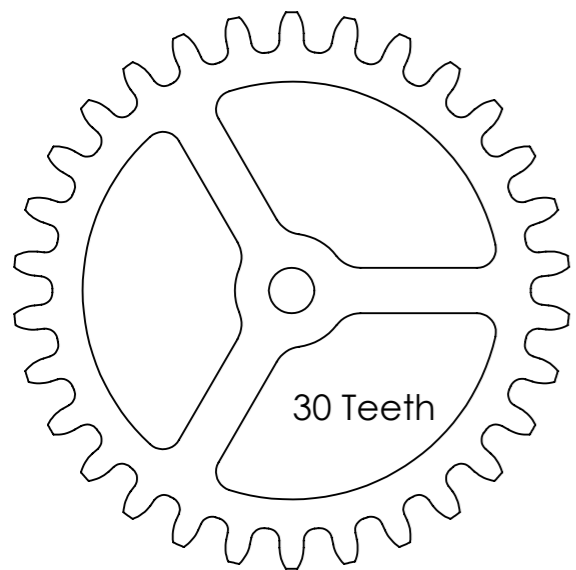

30 Teeth

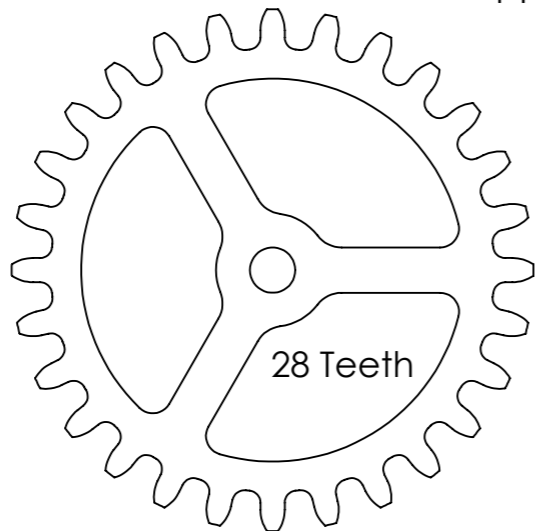

28 Teeth

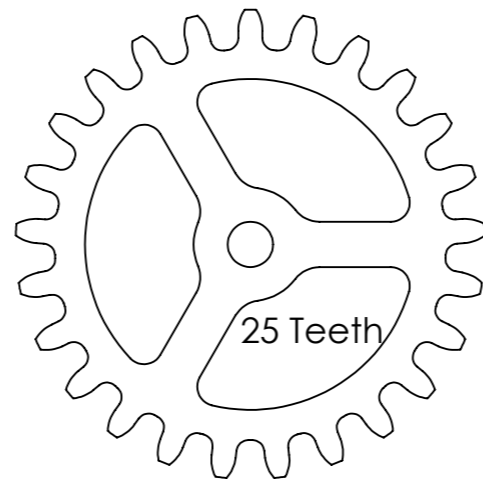

25 Teeth

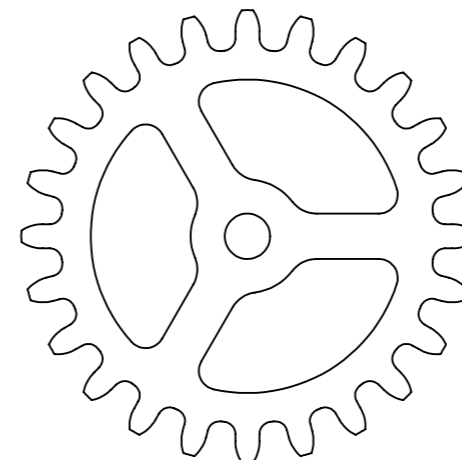

24 Teeth

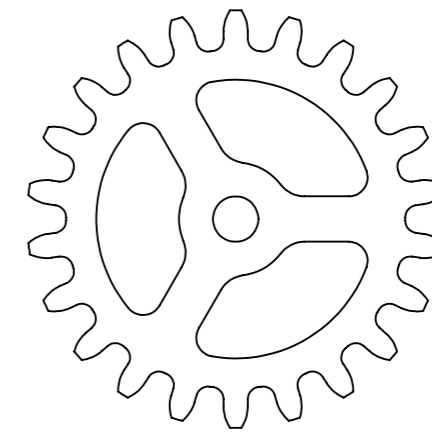

22 Teeth

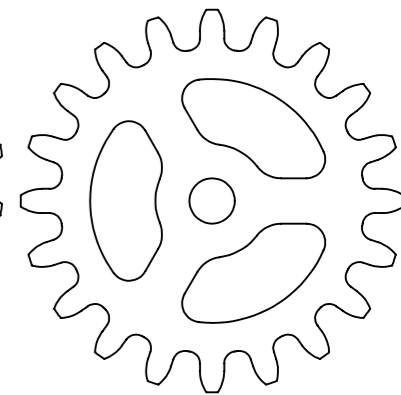

20 Teeth

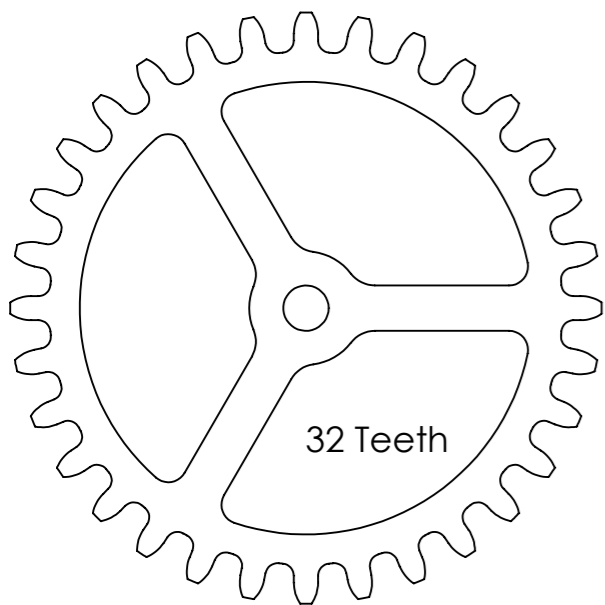

32 Teeth

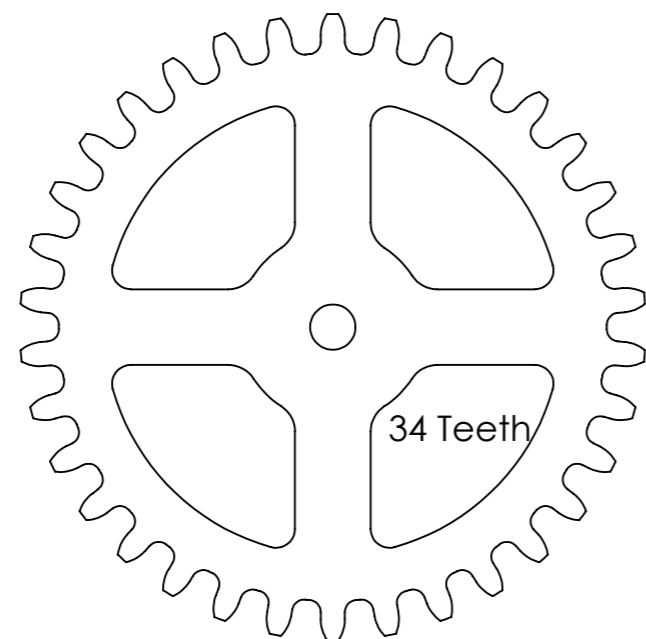

34 Teeth

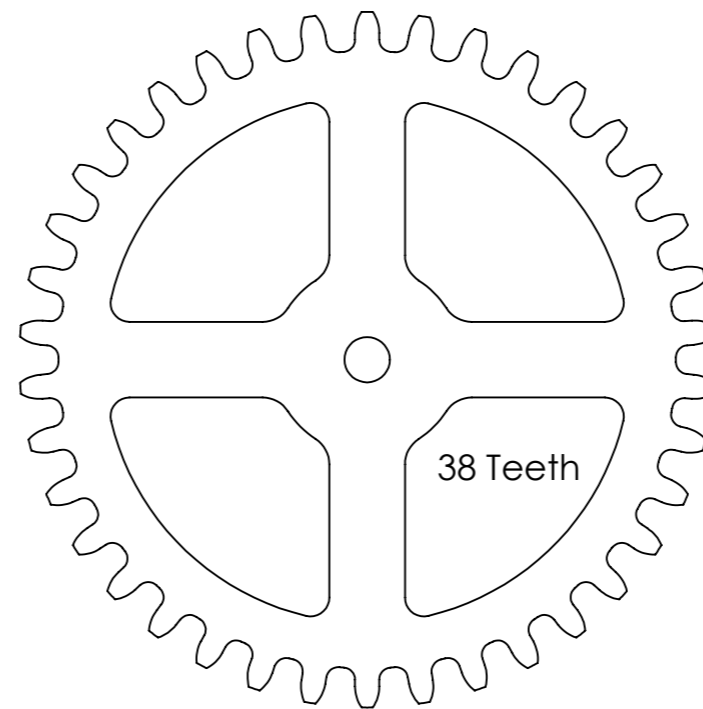

38 Teeth

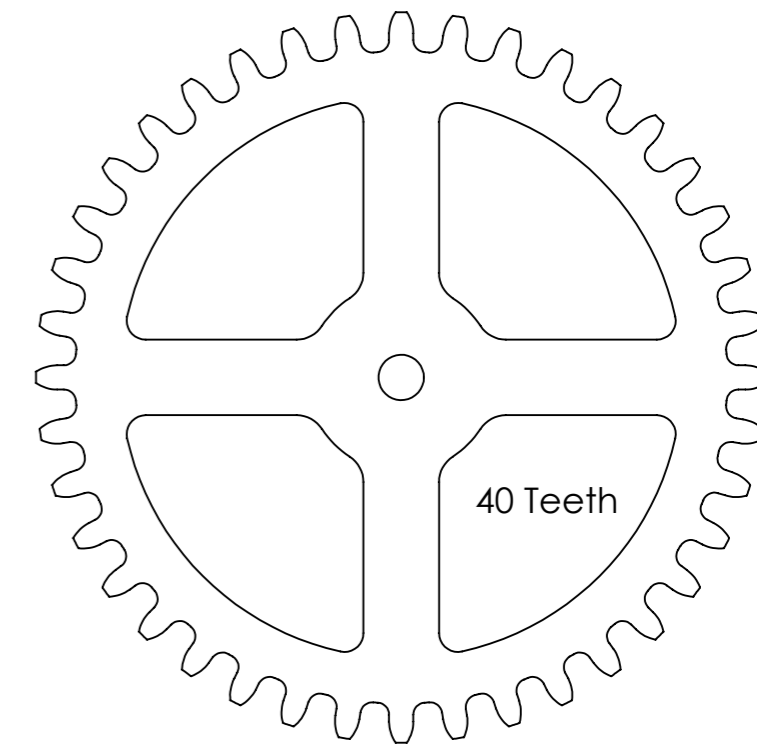

40 Teeth

Brian Law's Woodenclocks

A collection of Spur Gears based on the tooth profiles used in the woodenclocks

Brian Law February 2011 Sheet 2

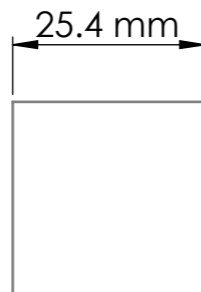

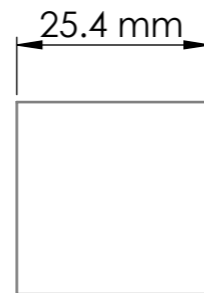
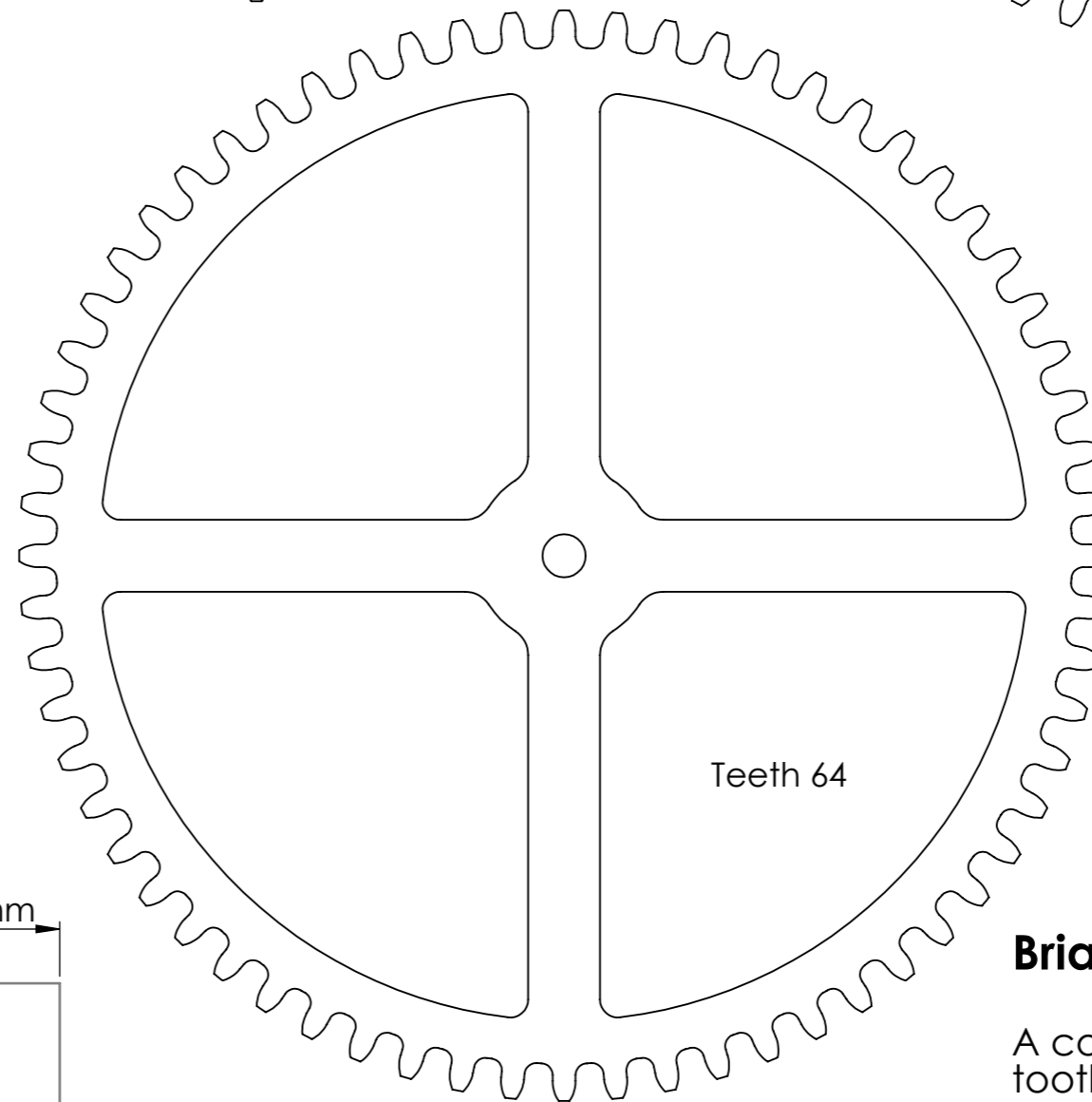
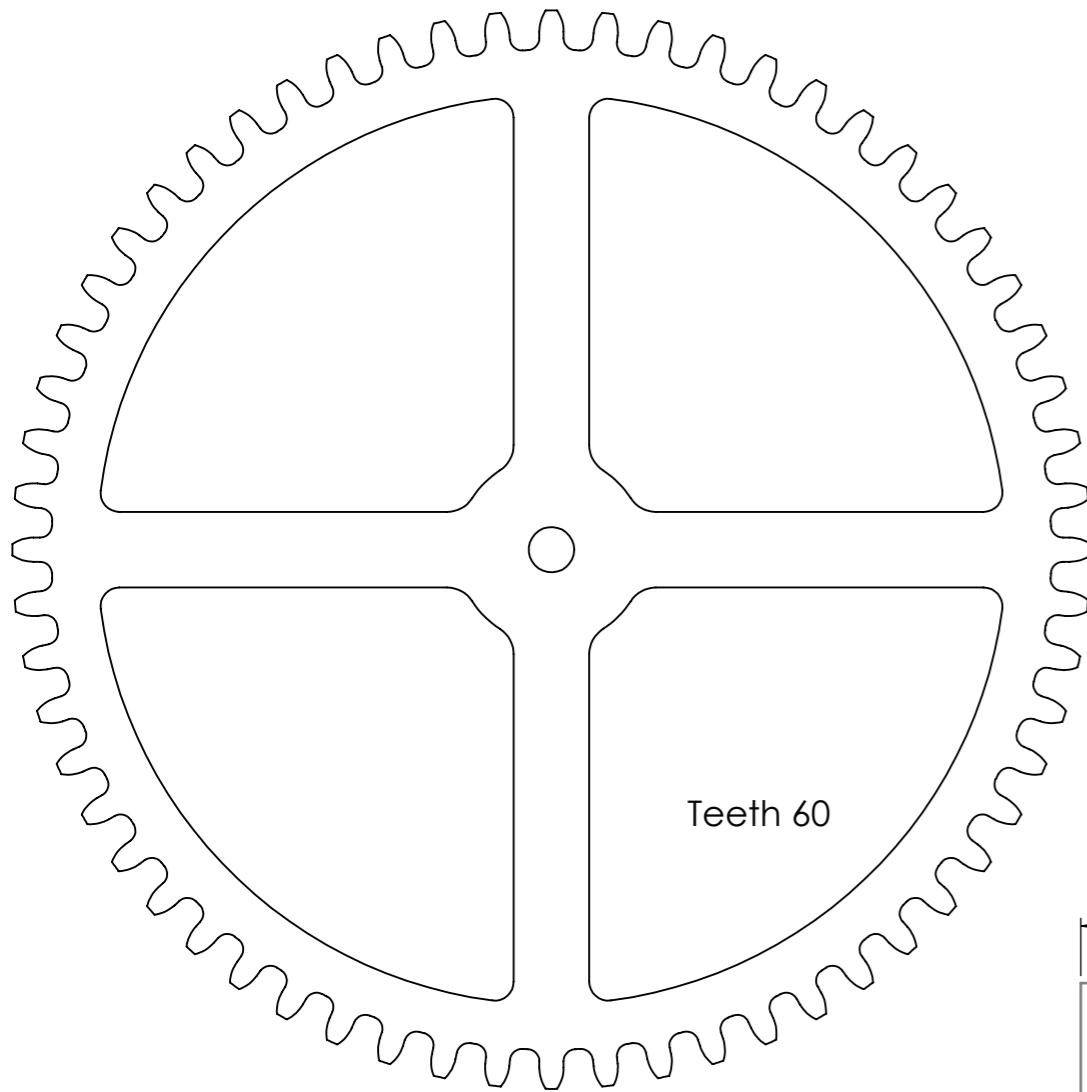
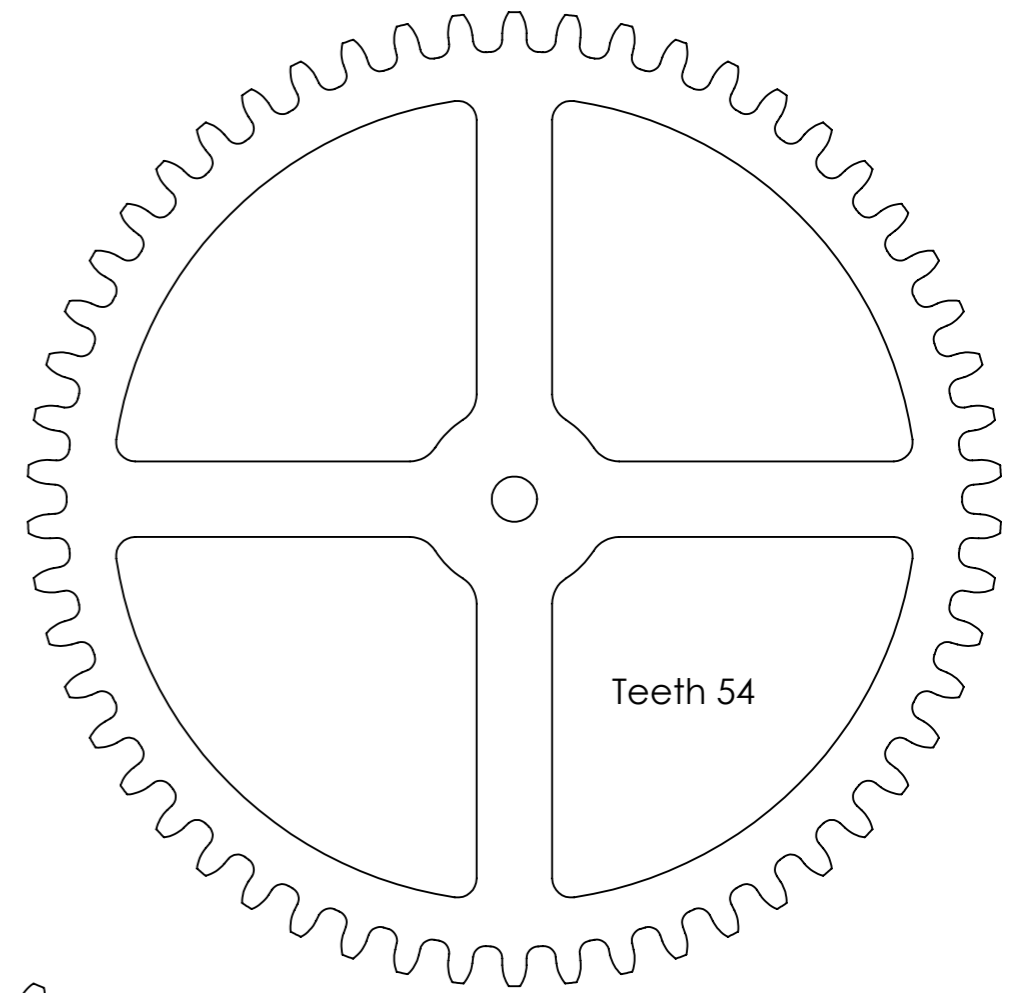
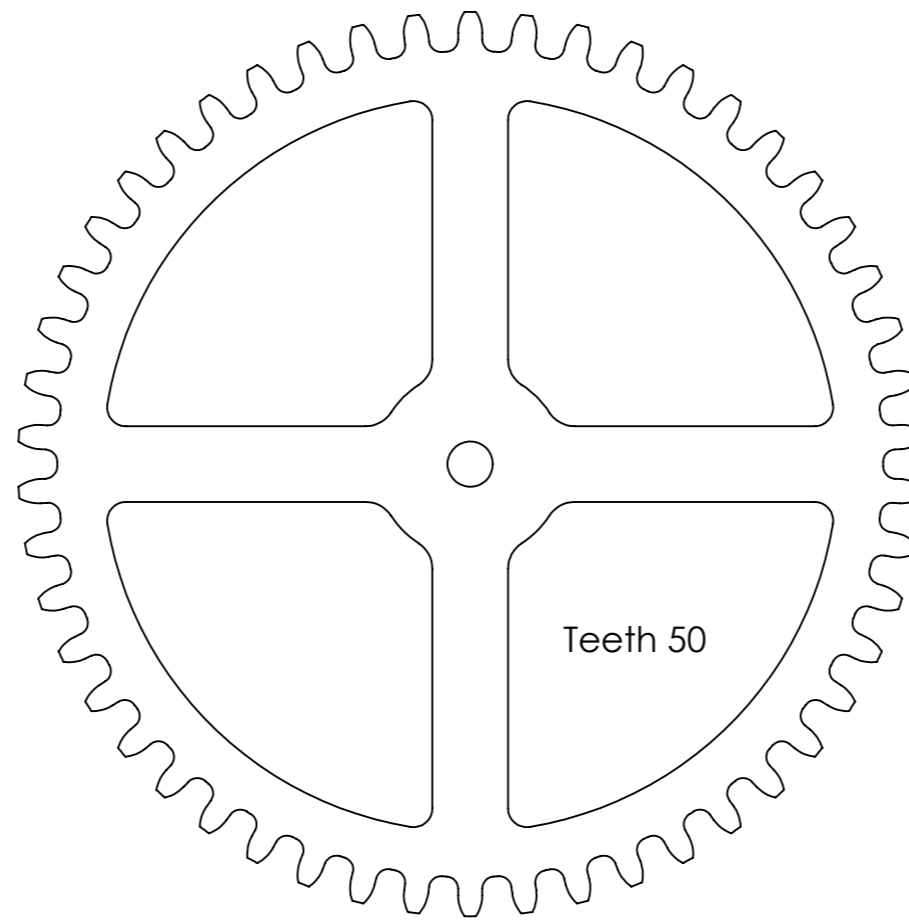
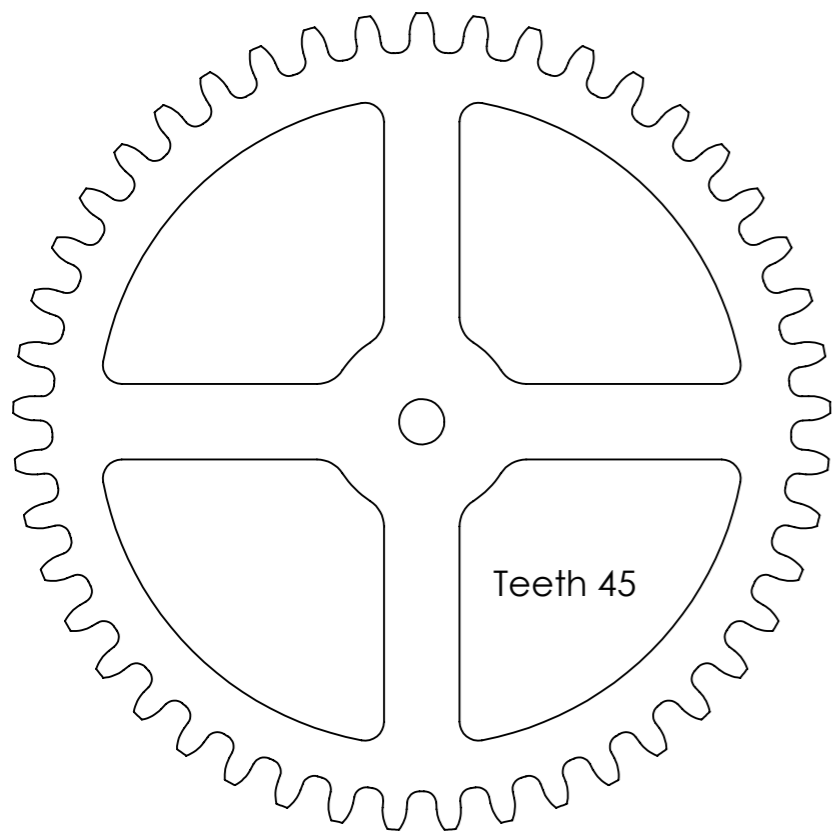

Brian Law's Woodenclocks

A collection of Spur Gears based on the tooth profiles used in the woodenclocks

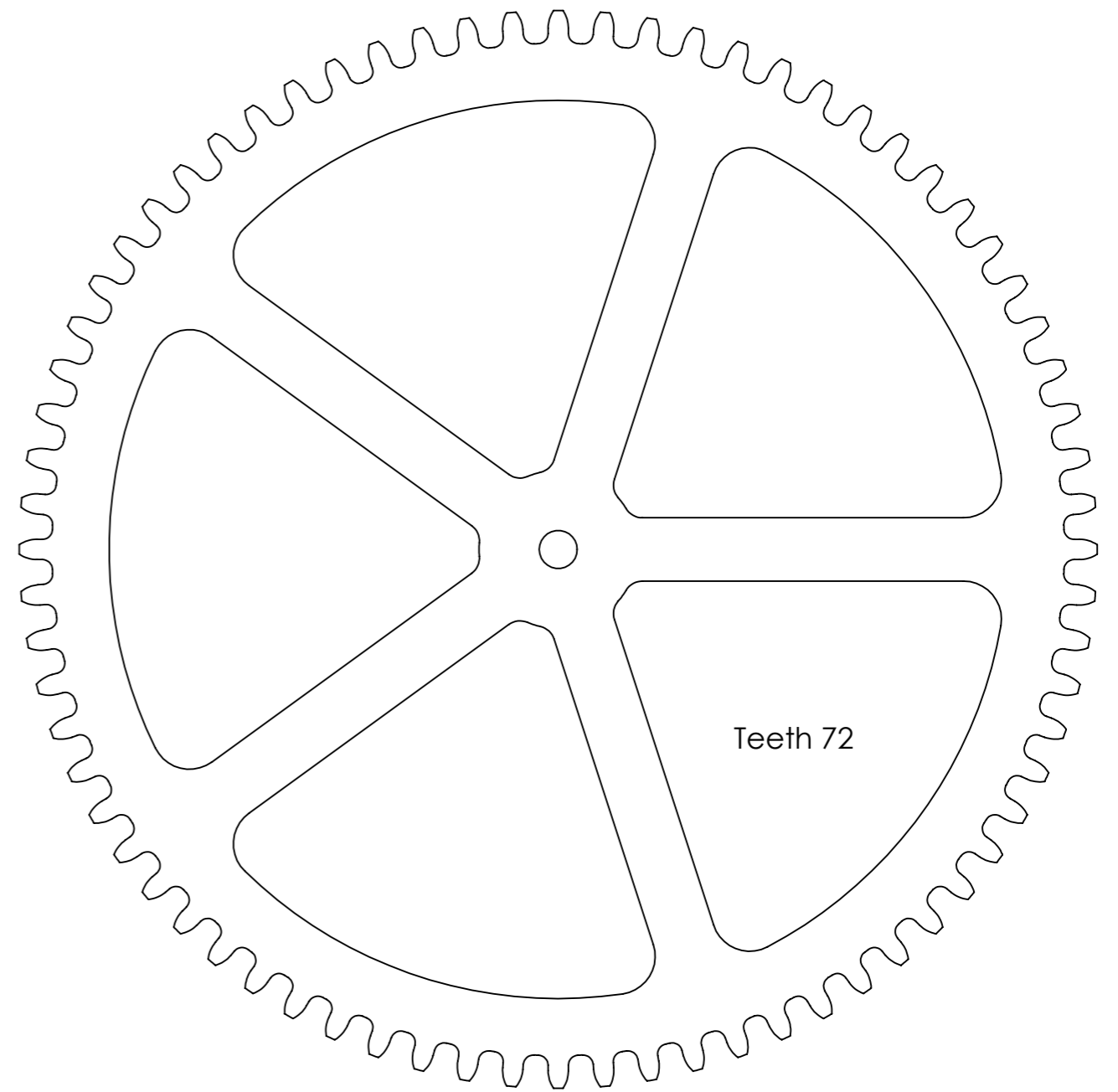
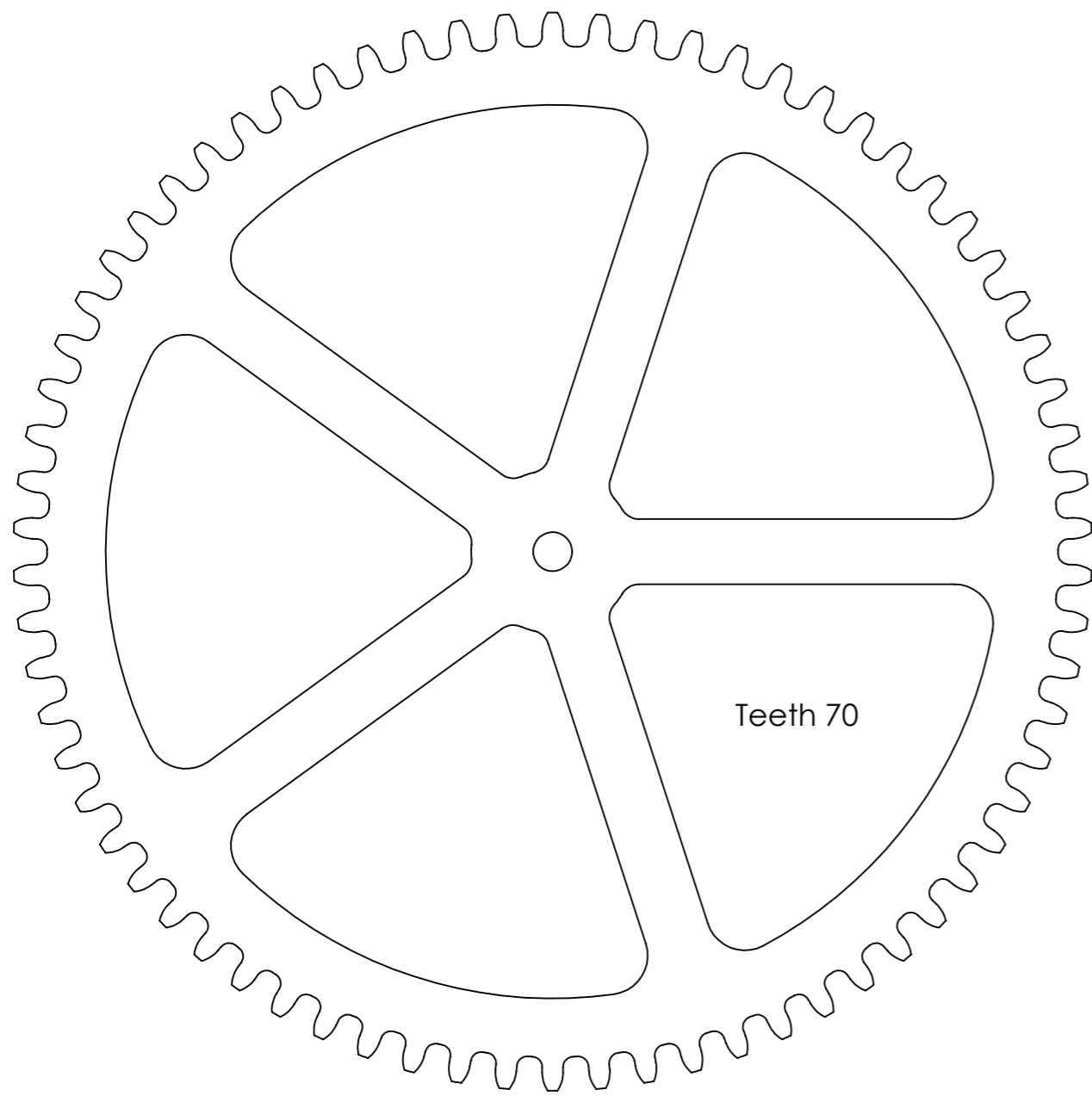

Brian Law's Woodenclocks

A collection of Spur Gears based on the tooth profiles used in the woodenclocks

Brian Law February 2011 Sheet 4

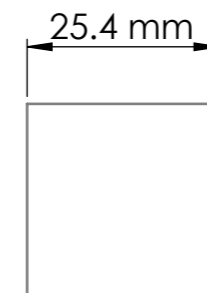
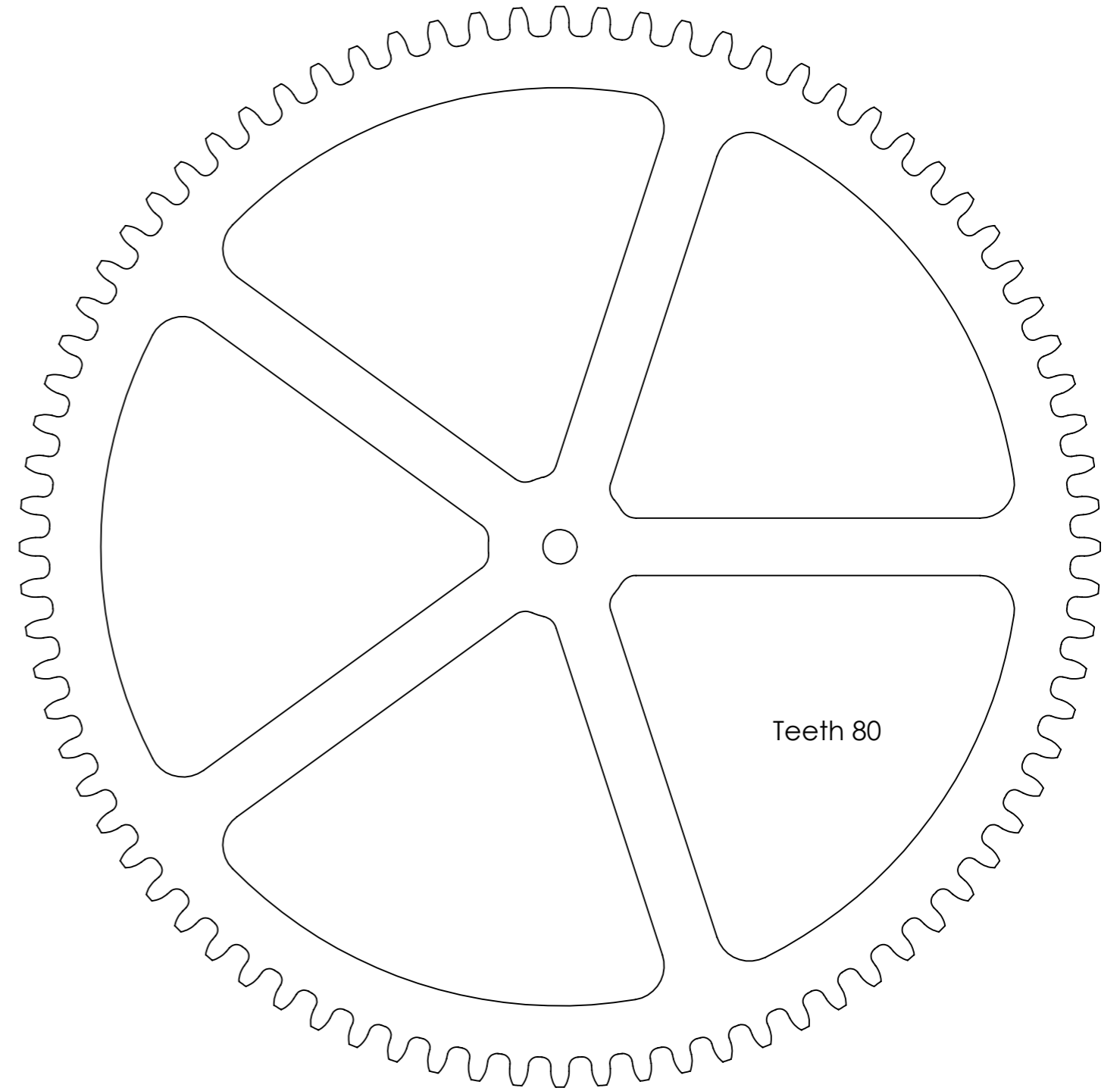
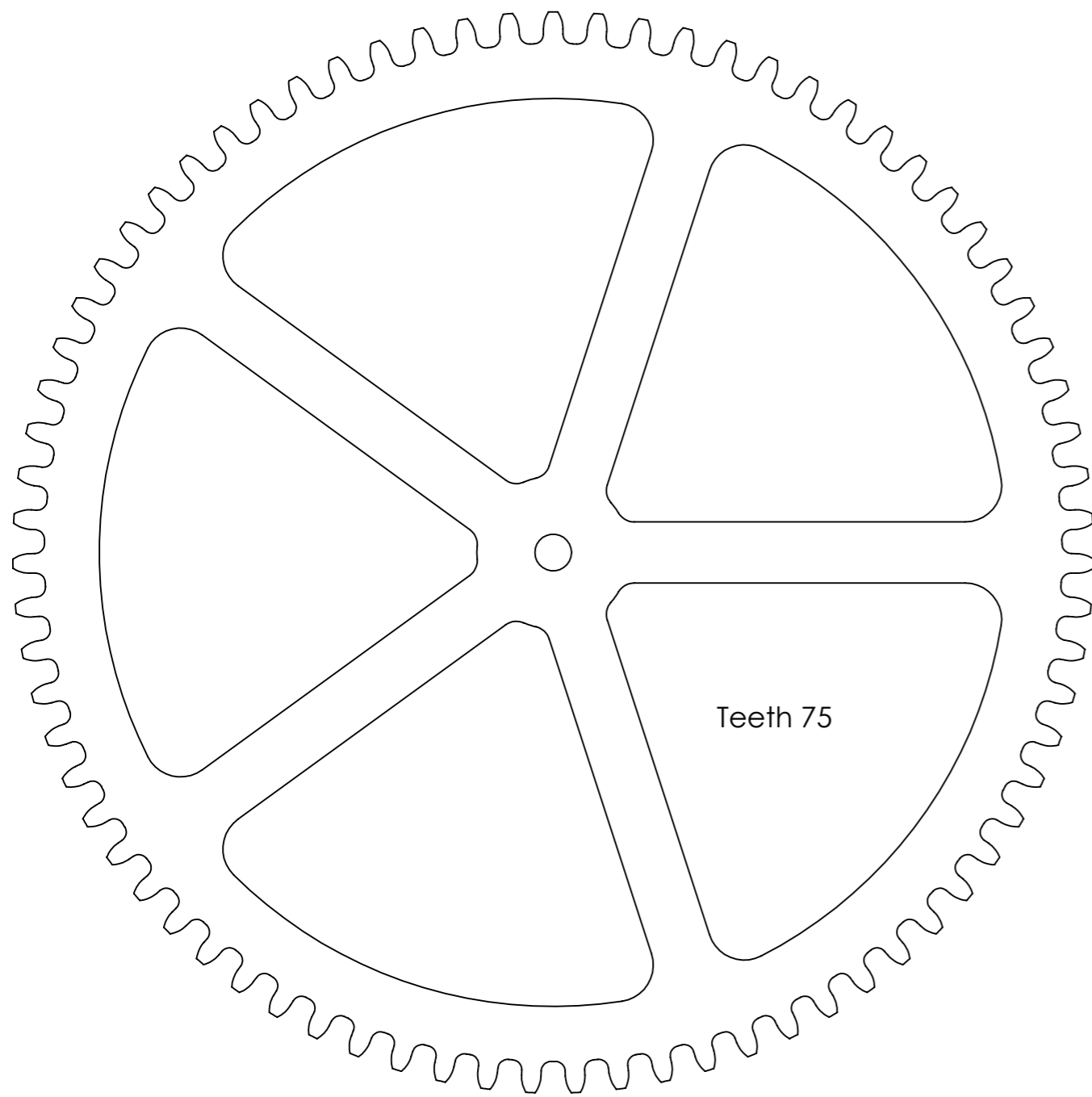

Brian Law's Woodenclocks

A collection of Spur Gears based on the tooth profiles used in the woodenclocks

Brian Law February 2011 Sheet 5

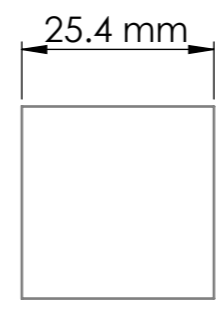
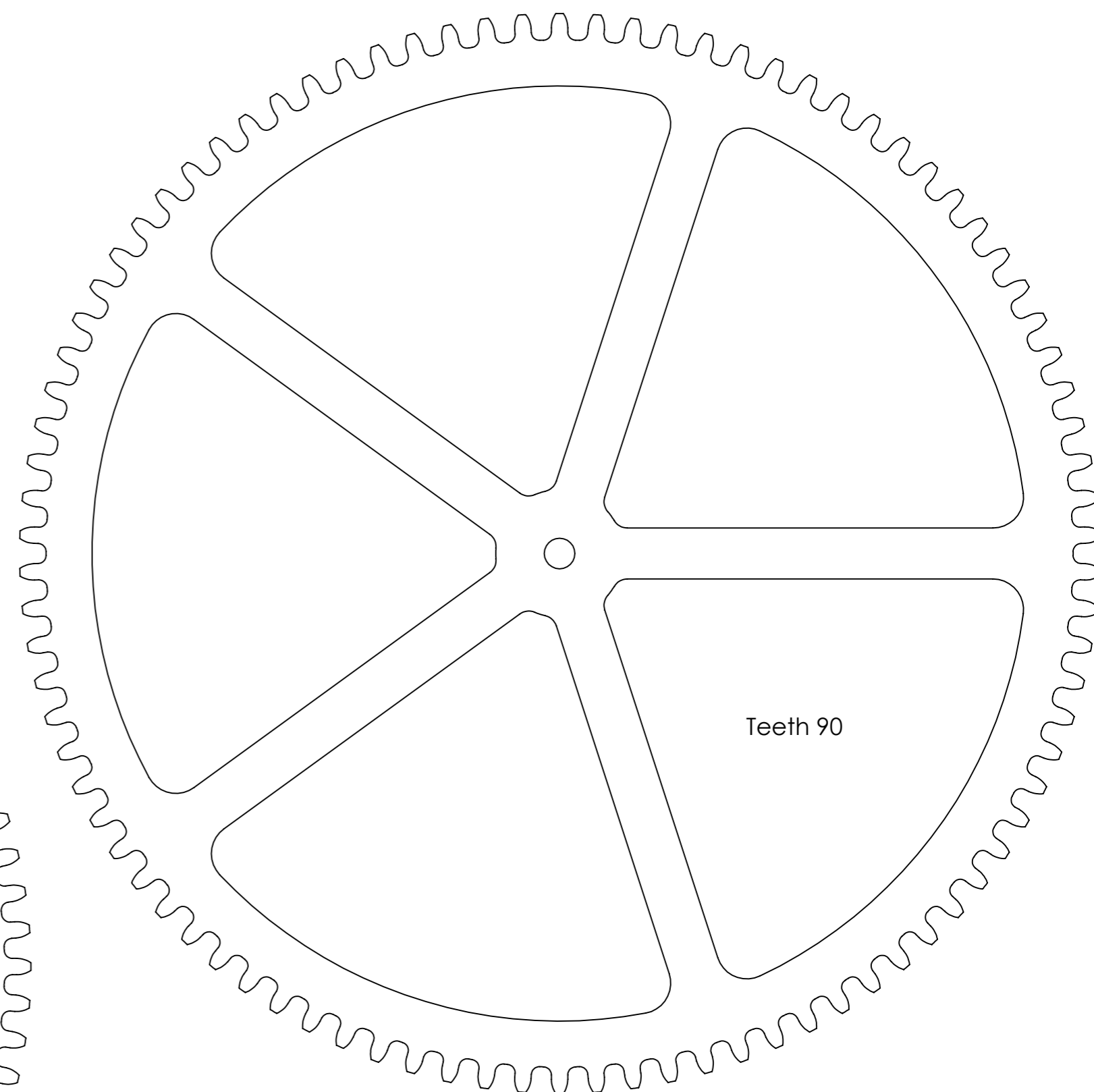
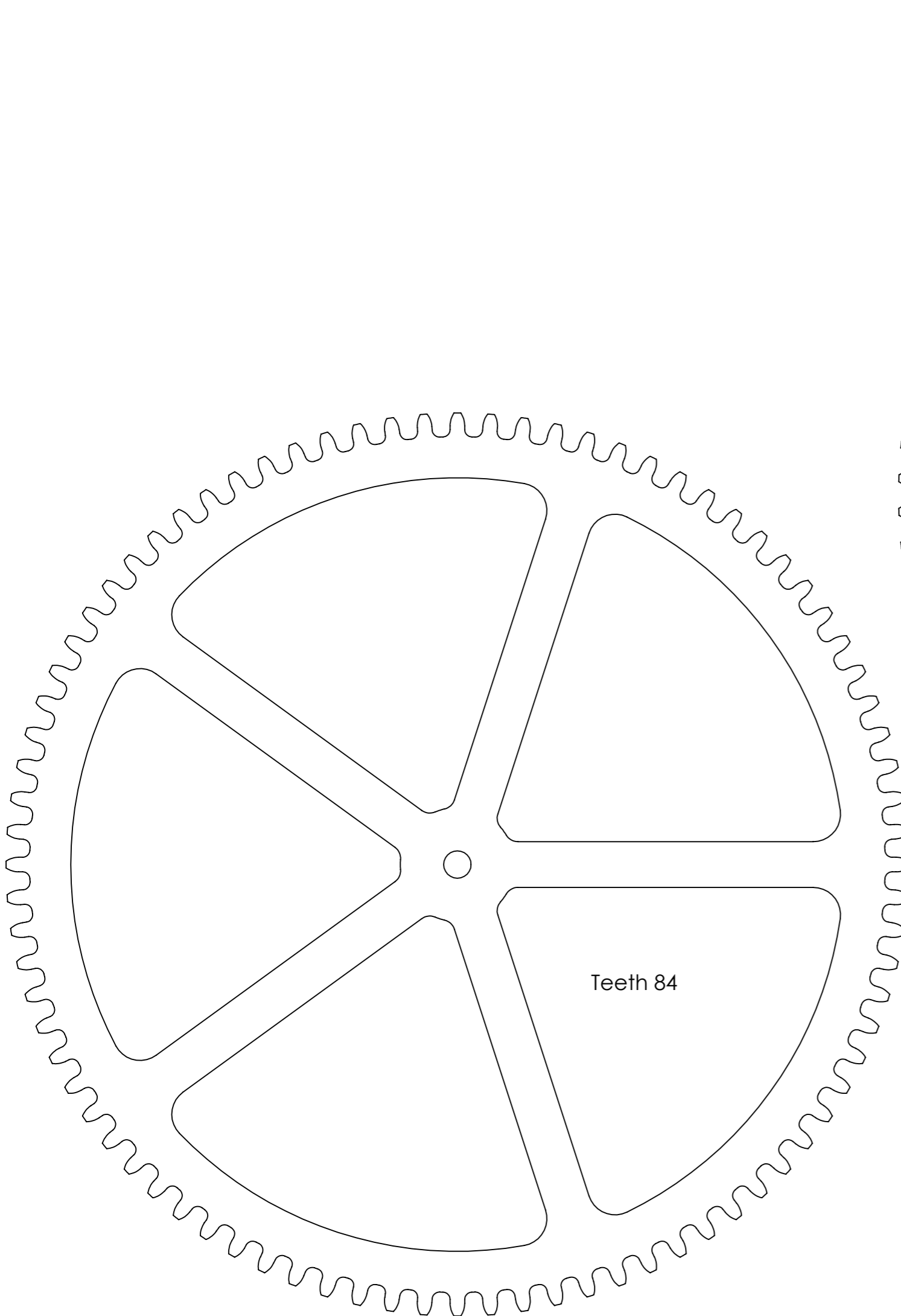

Brian Law's Woodenclocks

A collection of Spur Gears based on the tooth profiles used in the woodenclocks

Brian Law February 2011 Sheet 6

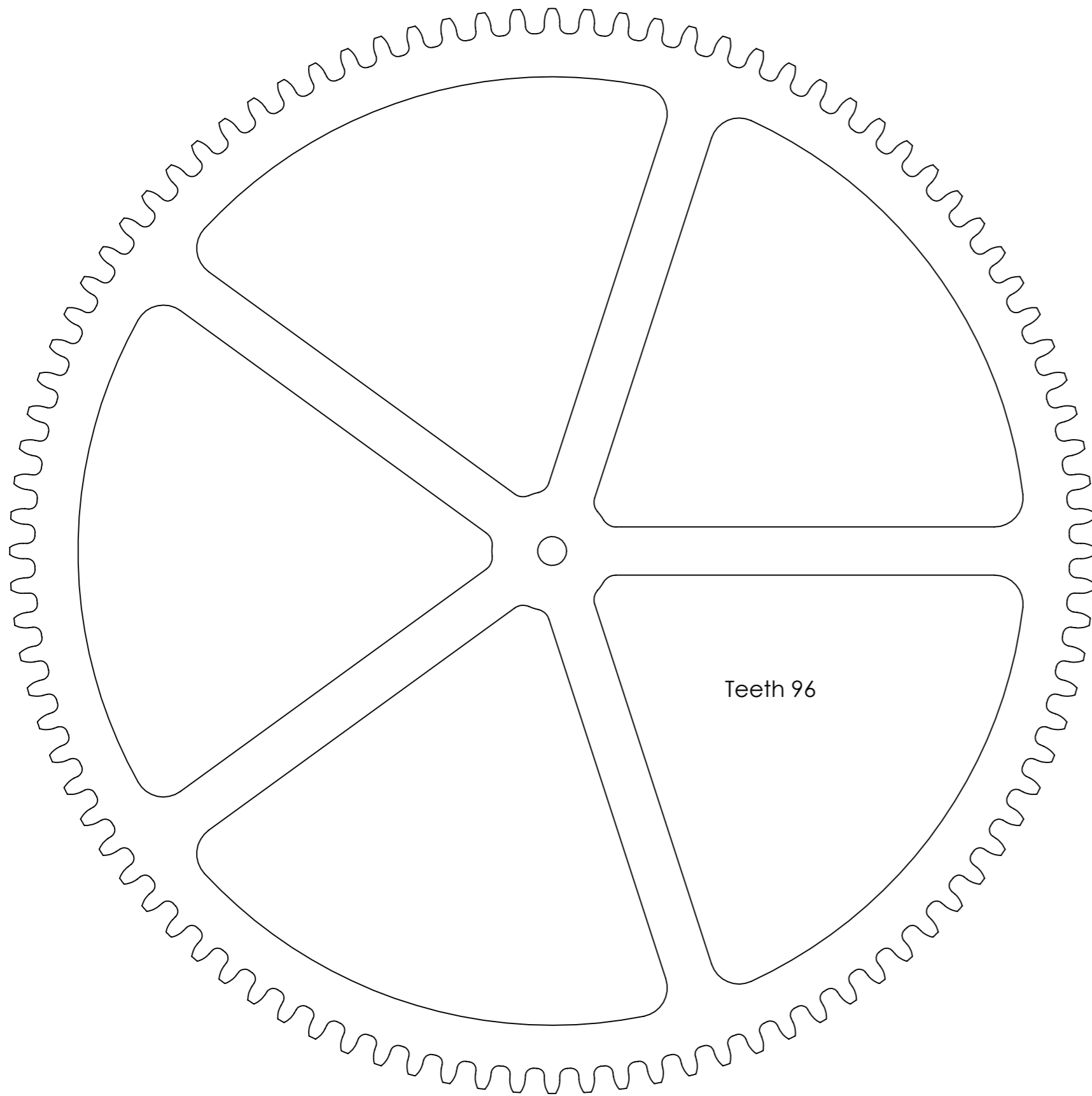

Teeth 96

25.4 mm

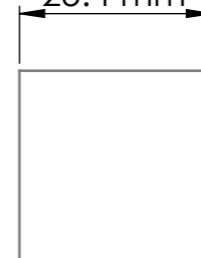

Brian Law's Woodenclocks

A collection of Spur Gears based on the tooth profiles used in the woodenclocks

Brian Law February 2011 Sheet 7

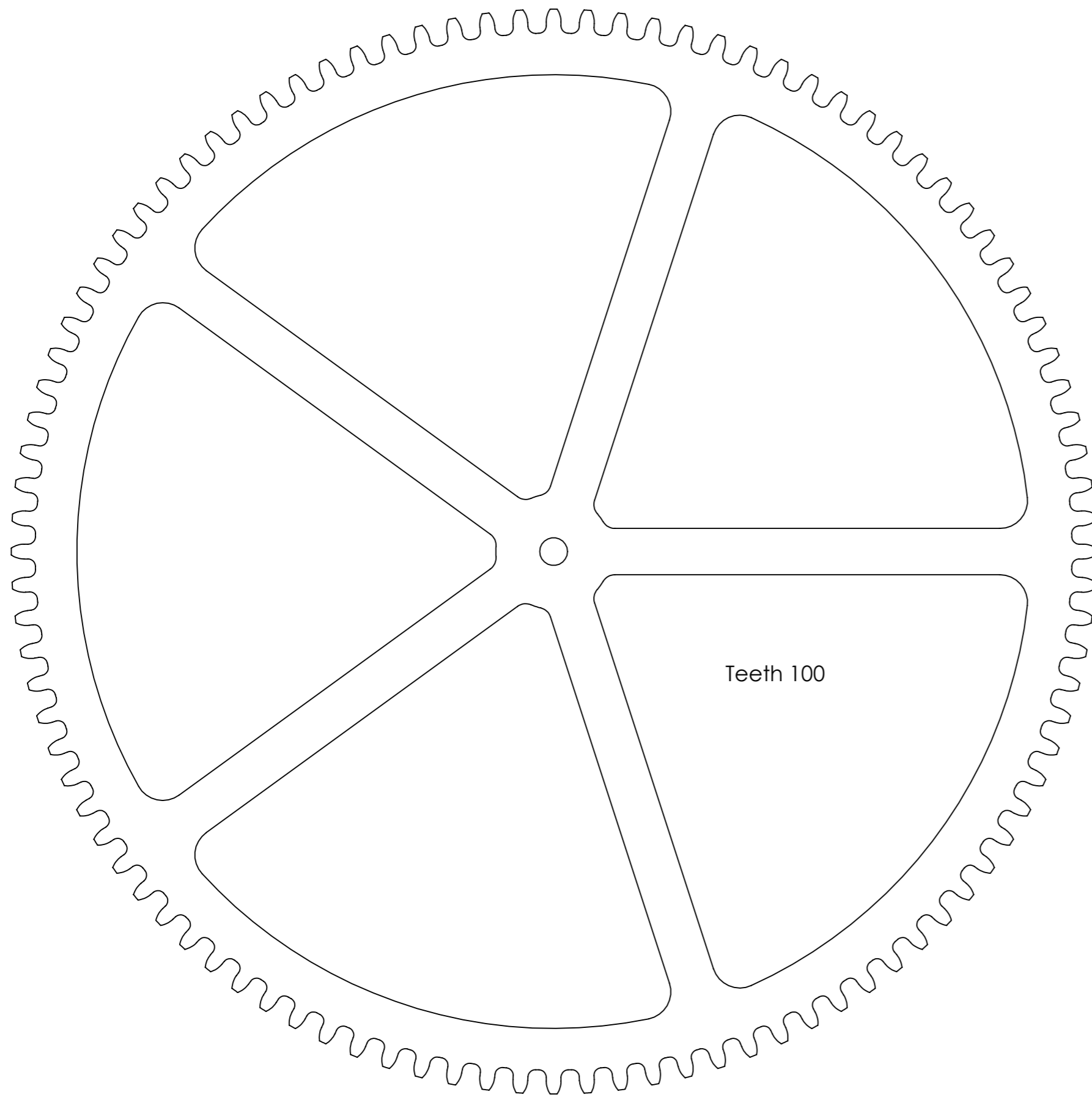

Teeth 100

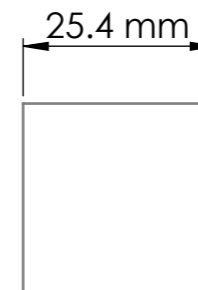

Brian Law's Woodenclocks

A collection of Spur Gears based on the tooth profiles used in the woodenclocks

Brian Law February 2011 Sheet 8